



Split Body Flange End Ball valve

Model: ED-2F

Design feature:

- With ISO 5211 Mounting Pad and **Center Ring**, pre-Drilled Metric Thread for easy automation.
- Designed to be fire-safe to minimize both external and internal fluid leakage after plant fires.
- Metal-to-metal Fire-safe seat design, API 607 Fire-Safe approved.
- Self-adjusting stem packing assembly with Belleville spring for temperature fluctuations, vibration, and is secured.
- Double D Stem Head Design Provides Mounting Of The Lever.
- Bottom Entry Blow-Out Proof Stem & Antistatic Device design Provides Maximum Safety.
- Wide range of seat & seal materials is available.
- Investment cast body construction.
- DIN EN10204-3.1 Certificate Available

Standard:

- Basic Design to ANSI B16.34
- Flange Dimension to ANSI B16.5 Class 150.
- Face-to-face meets to ANSI B16.10 Class 150.
- Inspection & testing according to API 598.
- API 607 5th Edition Fire-Safe Test approved.
- PED 97/23/EC; ISO 9001



Specifications:

- Construction: bolted body side-entry floating ball design.
- Flow bore: full port.
- Rating: ANSI Class 150;
150 PSI Saturated Steam.
- Temperature: -20°F ~ 400°F (PTFE/ R.PTFE)
- Materials: ASTM CF8M, CF8, WCB
- Size range: 1/2"~4".

Dimensions List

Size	D	L	H	E	F	ISO 5211	Torque (IN-LB)	Cv
1/2	15	108	89.9	150	6.3	F04	88	30
3/4	20	117.6	98.6	150	6.3	F04	106	50
1	25	127	108	180	8	F05	132	100
1-1/4	32	139.7	117.4	180	8	F05	256	180
1-1/2	40	165.1	127	210	9.5	F07	354	250
2	50	177.8	152.4	210	9.5	F07	424	480
2-1/2	65	190.5	177.8	260	17	F07	585	750
3	76	203.2	190.5	260	17	F10	982	1300
4	97	228.6	228.6	310	17	F10	1239	2400

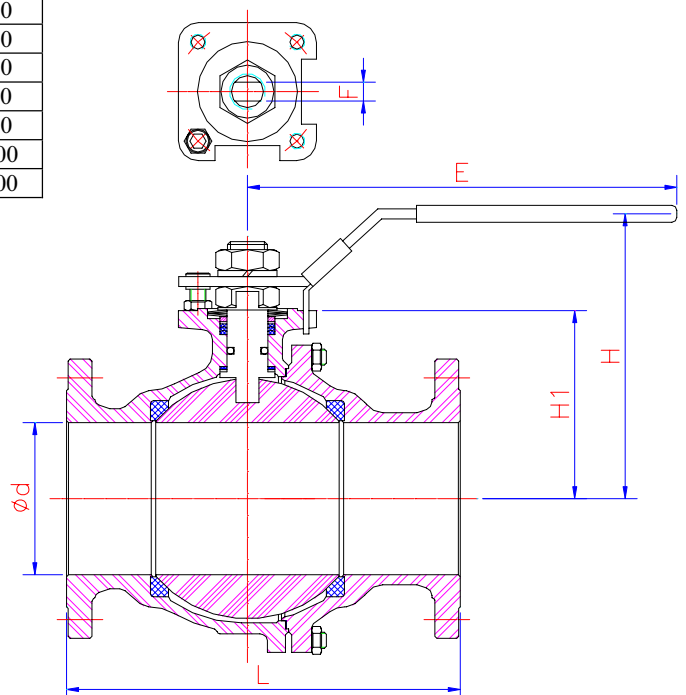
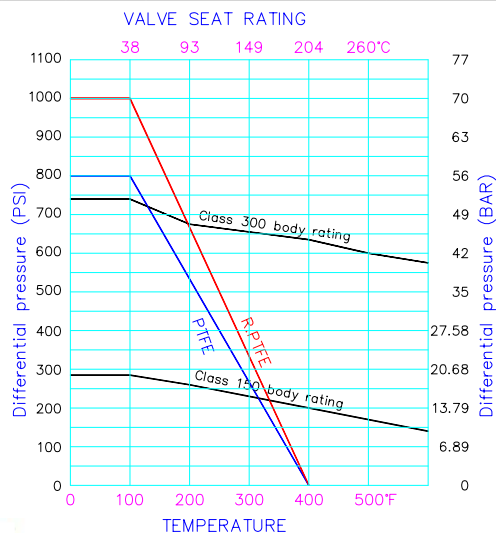

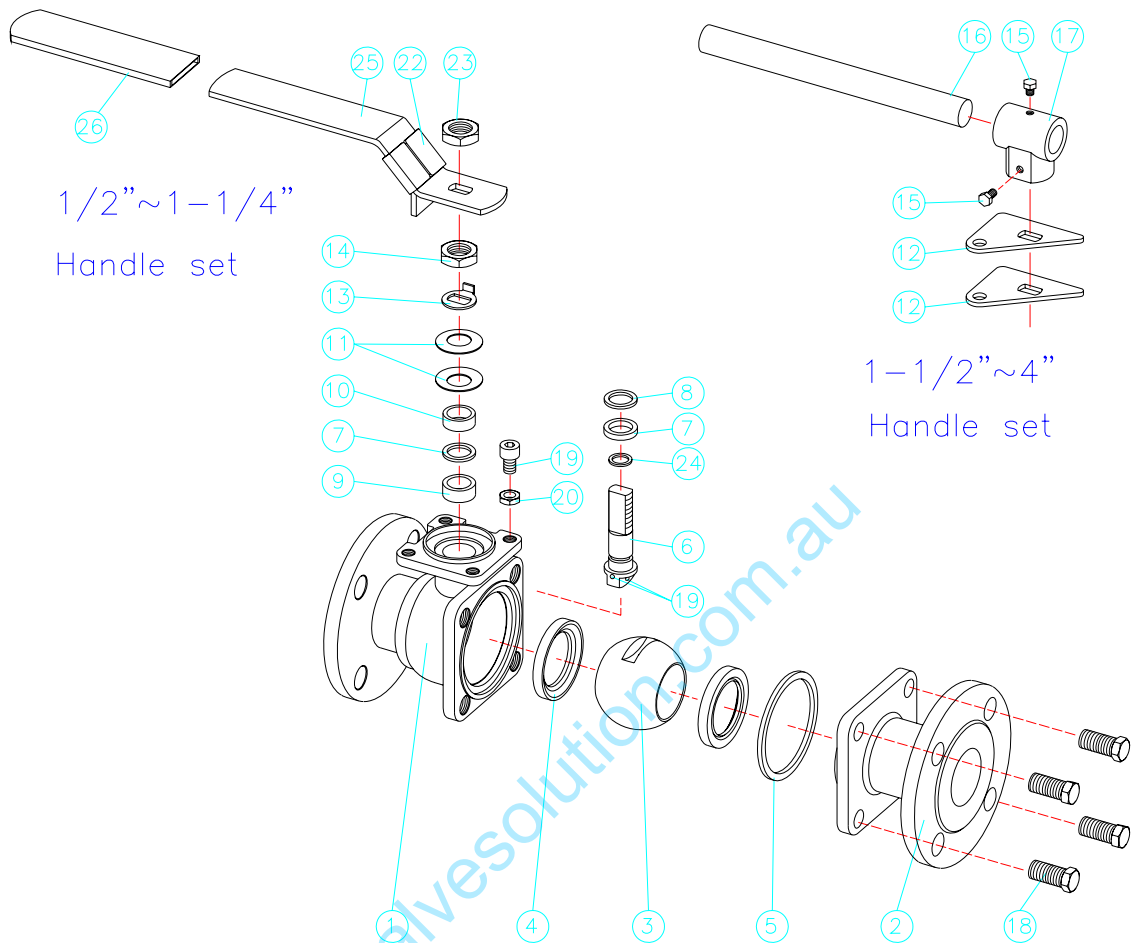

STANDARD TYPE MATERIALS LIST:

NO	PART NAME	MATERIAL	NO	PART NAME	MATERIAL
*1	BODY	CF8M/ CF8/ WCB	14	STEM NUT	SS304
*2	END CAP	CF8M/ CF8/ WCB	15	SADDLE NUT	SS304
*3	SOLID BALL	CF8M	16	HANDLE	SS304
4	BALL SEAT	15%GF + PTFE	17	HANDLE ADAPTER	SS304
5	BODY SEAL	15%GF + PTFE	18	BODY BOLT	SS304
*6	STEM	SS316	19	ANTI-STATIC DEVICE	SS316
7	THRUST WASHER	50%SS +50%PTFE	20	STOP BOLT	SS304
8	STEM SEAL	PTFE	21	STOP NUT	SS304
9	STEM PACKING	PTFE	22	LOCKING DEVICE	SS304
10	GLAND	SS304	23	HANDLE NUT	SS304
11	BELLEVILLE SPRING	SUS301	24	O-RING	VITON
12	TRAVEL STOPPER	SS304	25	HANDLE	SS304
13	LOCK SADDLE WASHER	SS304	26	HANDLE SLEEVE	VINYL

*note: Alloy 20, Duplex 2205, Hastelloy C and other special alloy upon request.

FIRE-SAFE TYPE MATERIALS LIST:

NO	PART NAME	MATERIAL
4	BALL SEAT	PTFE
5	BODY SEAL	GRAPHITE
8	STEM SEAL	GRAPHITE
9	STEM PACKING	GRAPHITE